

OILER KIT ASSEMBLY

FOR ALASKAN MILL MK III MODEL G801A

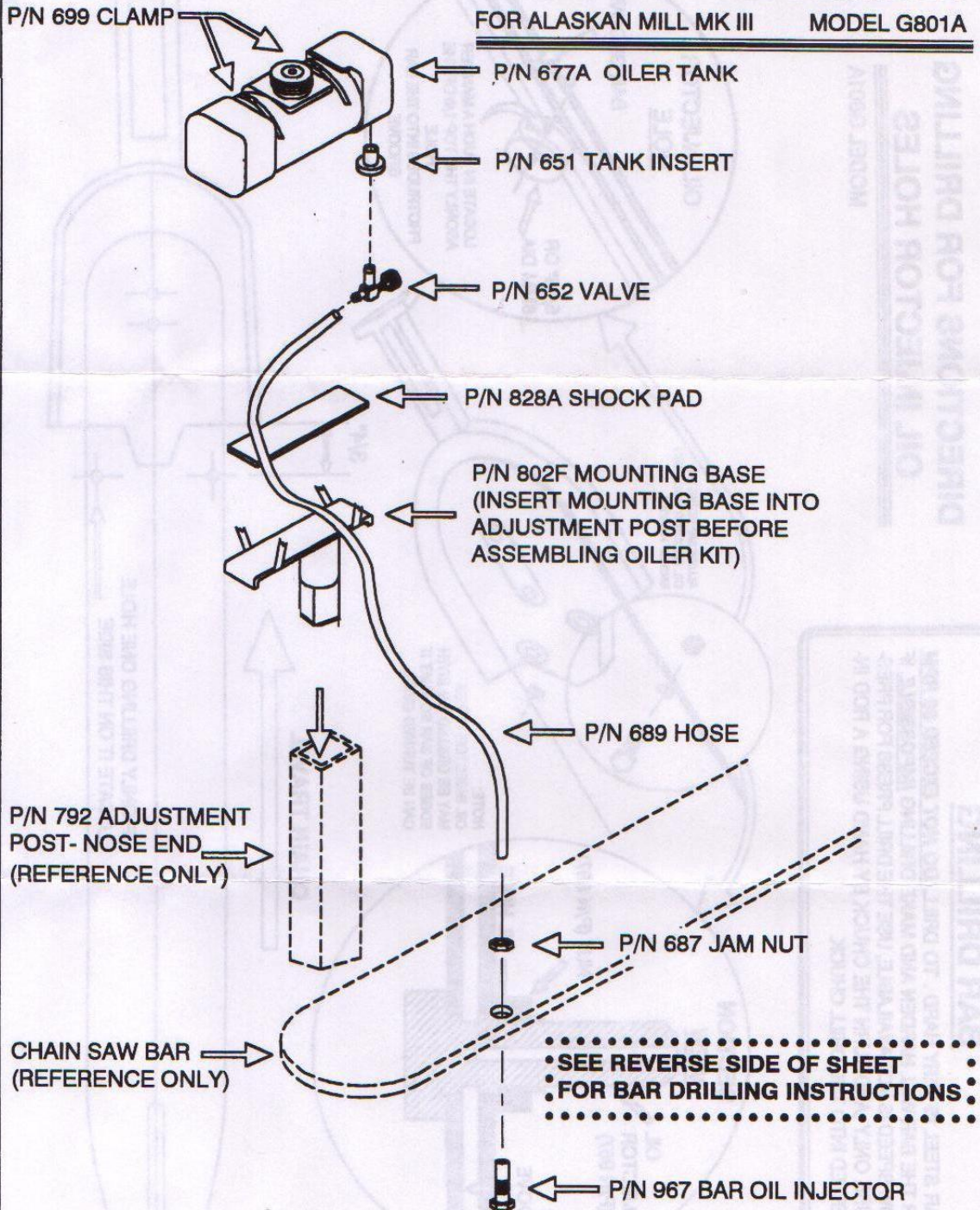

BAR DRILLING

BAR STEEL IS VERY HARD. TO DRILL, DO NOT EXCEED 80 RPM OR THE BAR WILL HARDEN AND MAKE DRILLING IMPOSSIBLE. IF LOW SPEED IS NOT AVAILABLE, USE THE DRILL PRESS FOR PRESSURE ONLY, AND TURN THE CHUCK BY HAND USING A ROD INSERTED INTO THE DRILL CHUCK.

DIRECTIONS FOR DRILLING OIL INJECTOR HOLES

MODEL G801A

